

# Wiper Direct Actuator WDA

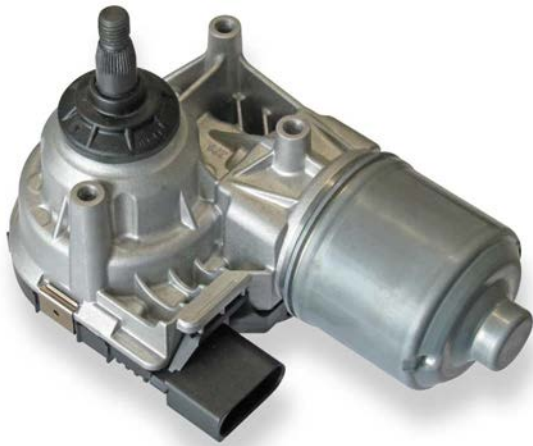

- ▶ Analog and LIN versions available
- ▶ Optimized hardware for motorsport applications
- ▶ Customer specific calibration of wiping angles and speed

The WDA is a wiper motor designed to execute reversing movements instead of rotating 360° like a conventional wiper.

Its function and many operating modes are managed by integrated control electronics. The user is able to control the desired operating mode simply by switching its analog inputs to ground (Analog version) or via LIN (LIN version). The gear, the motor and the electronics are all installed in the same housing.

The main benefit of this wiper motor is its direct rotation movement which replaces external gears and the possibility of programming the operating speed and end positions of all its function modes, upon request.

## Application

Operating temperature range -40 to 85°C

## Technical Specifications

**WDA Analog** Operating modes

- Stop
- Interval
- Speed 1
- Speed 2

**WDA LIN** Operating modes

- Stop
- Interval
- Speed 1
- Speed 2
- Single stroke

## Mechanical Data

Size 104.7 x 174.7 x 117.1 mm

Max. wipe cycles/min Depending on wipe angle

Max. wipe angle 160°

Max. torque	35 Nm
Weight	1,270 g
Max. vibration	30 % of Vibration Profile 1 or 100 % of Vibration Profile 1 in combination with silentlocks (see <a href="http://www.bosch-motorsport.com">www.bosch-motorsport.com</a> )

## Electrical Data

Power supply	9 to 16 V
Supply current at 40 cycles/min.	Typ. 3.4 A
Supply current at 60 cycles/min.	Typ. 6.3 A

## LIN Protocol

LIN Version	2.0
LIN Speed	19.2 kbaud
Message ID	0x31

BYTE 0 Value	0	0	Kl. X	Kl. 15	Counter
Bit	7	6	5	4	3 2 1 0

BYTE 1 Value	SPD2	SPD1	INT	SST	INT Mode
Bit	7	6	5	4	3 2 1 0

BYTE 2 Value	0	0	0	0	0 0 0 0
Bit	7	6	5	4	3 2 1 0

BYTE 3 Value	0	0	0	0	0	0	0	0	0
Bit	7	6	5	4	3	2	1	0	0
BYTE 4 Value	0	0	0	0	0	0	0	0	0
Bit	7	6	5	4	3	2	1	0	0
BYTE 5 Value	0	0	0	0	0	0	0	0	0
Bit	7	6	5	4	3	2	1	0	0

Byte	Bit	Signal	Explanation	Values [dez]
0	0 to 3	Counter	The counter has to be increased with each LIN-message	0 to 15
0	4	Kl. 15	Clamp 15 Bit has to be enabled for operation	ON=1 OFF=0
0	5	Kl. X	Clamp X Bit has to be enabled for operation	ON=1 OFF=0
1	0 to 3	INT Mode	Interval Mode (enabled if operation mode interval is set)	Interval speed: 1=1 2=5 3=9 4=13
1	4	SST	Single stroke operation mode (enabled once if Bit is set temporary)	ON=1 OFF=0
1	5	INT	Operation mode interval	ON=1 OFF=0
1	6	SPD1	Operation mode speed 1	ON=1 OFF=0
1	7	SPD2	Operation mode speed 2	ON=1 OFF=0
		STOP	Operation mode stop is enabled if SST, INT, SPD1 and SPD2 are OFF (default)	

**Connectors and Wires**

Connector	CEP2M-AMP-4
Mating connector	F02U.B00.542-01
Various motorsport and automotive connectors available on request	

**Pinout Analog**

Pin 1	AN2
-------	-----

Pin 2	AN1
Pin 3	Gnd
Pin 4	U <sub>s</sub>

**Pinout LIN**

Pin 1	LIN
Pin 2	Special functions, e.g. Master/Slave
Pin 3	Gnd
Pin 4	U <sub>s</sub>

**Installation Notes**

Typical lifetime: max. 220 h / 1 year

For application with severe conditions and/or high volume, please contact your Bosch Motorsport counterpart in order to define the most appropriate validation program

The WDA Analog can be operated by switching the analog inputs between ground and voltage supply.

The WDA LIN can be operated by all ECUs with LIN 2.X Master function. Further information about the LIN-Frame available upon request.

Make sure that the wiper is in its workspace when restarting after a power failure (upper and lower limit).

Please contact us to define the desired angle of all the operating modes.

The acceleration values can be exceeded by using silentblocks (F02U 003 027-01).

Please ensure that the environmental conditions do not exceed the specifications.

Please find further application hints in the offer drawing at our homepage.

Please deliver the calibration sheet with your order placement.

LIN ID 0x32 (Tx) is used for internal WDA diagnostic purposes. Make sure that the LIN ID 0x32 is not used in your LIN network by any other device.

**Delivery Status**

The motor will be delivered with three mounting screws. The screws are pre-assembled with a few thread turns.

- Self-tapping screw referred to DIN 7500
- PE M6x20
- Maximum tightening torque: 8 Nm

**Ordering Information**

**WDA LIN**  
Order number **F02U.V00.838-04**

**WDA Analog**  
Order number **F02U.V00.938-03**

**Accessories**

**Silentblock**  
Order number **F02U.003.027-01**

Dimensions

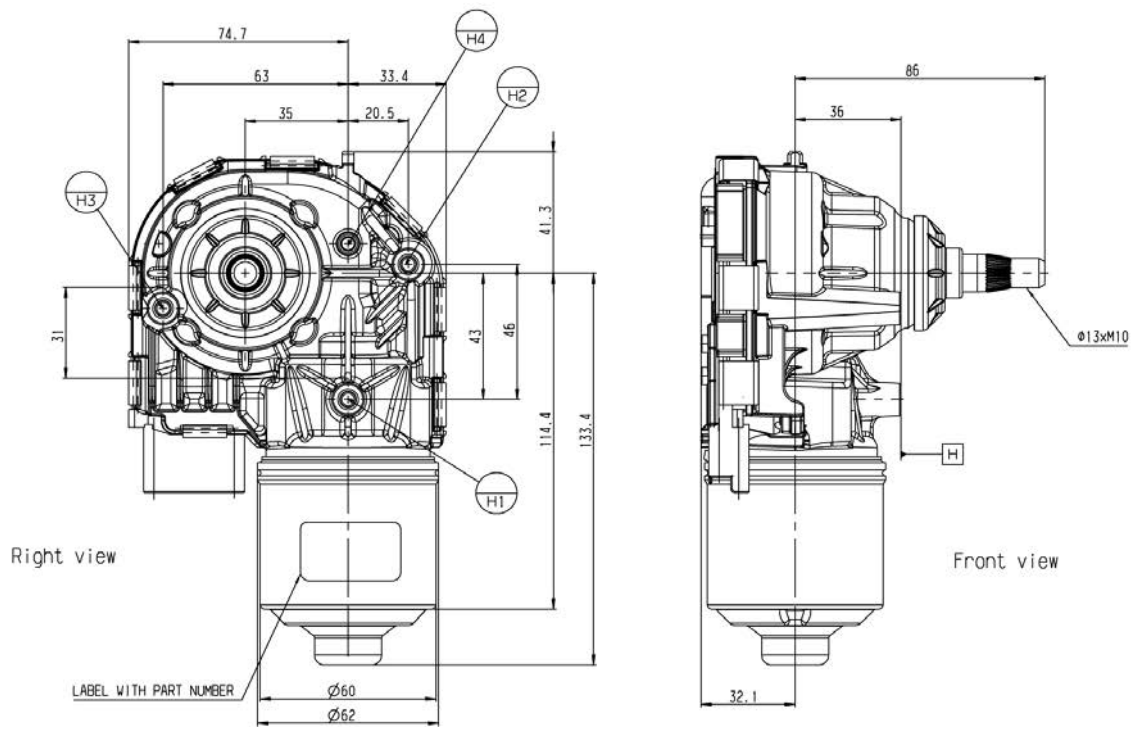

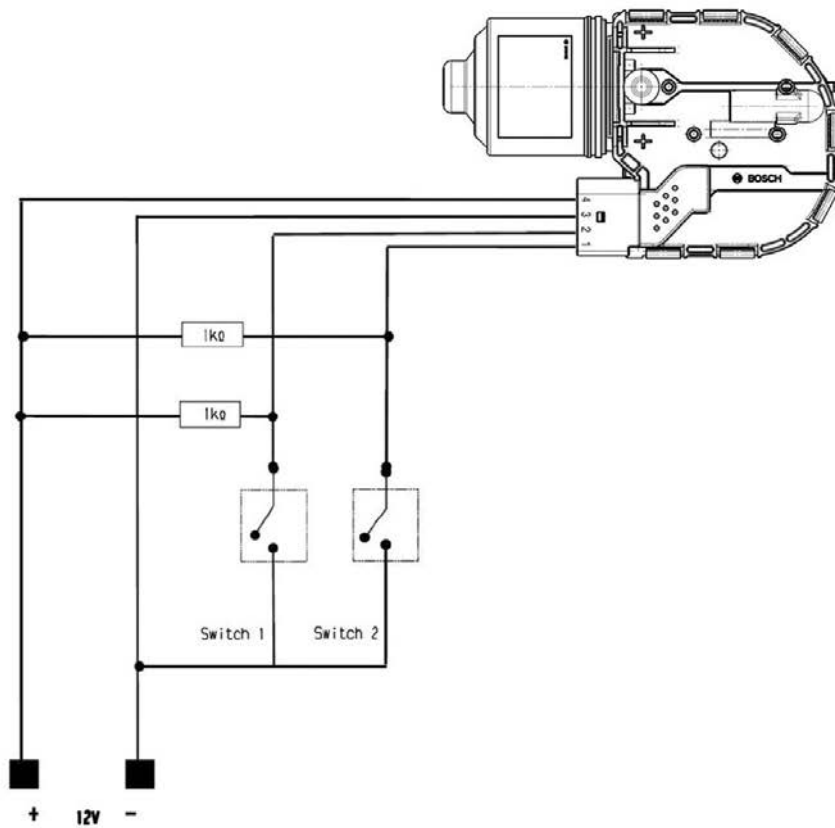

Operating modes referring analog inputs configuration

Operating Mode	AN1 (Pin 2)	AN2 (Pin 1)
Stop	Power Supply	Power Supply
Interval	Power Supply	GND
Speed 1	GND	GND
Speed 2	GND	Power Supply

Operating modes referring switch configuration

Operating Mode	Switch 1	Switch 2
Stop	opened	opened
Interval	opened	closed
Speed 1	closed	closed
Speed 2	closed	opened

**Represented by:**

**Europe:**  
 Bosch Engineering GmbH  
 Motorsport  
 Robert-Bosch-Allee 1  
 74232 Abstatt  
 Germany  
 Tel.: +49 7062 911 9101  
 Fax: +49 7062 911 79104  
 motorsport@bosch.com  
 www.bosch-motorsport.de

**North America:**  
 Bosch Engineering North America  
 Motorsport  
 38000 Hills Tech Drive  
 Farmington Hills, MI 48331-3417  
 United States of America  
 Tel.: +1 248 876 2977  
 Fax: +1 248 876 7373  
 motorsport@bosch.com  
 www.bosch-motorsport.com

**Asia-Pacific:**  
 Bosch Engineering Japan K.K.  
 Motorsport  
 18F Queen's Tower C, 2-3-5 Minato  
 Mirai Nishi-ku, Yokohama-shi  
 Kanagawa 220-6218  
 Japan  
 Tel.: +81 45 650 5610  
 Fax: +81 45 650 5611  
 www.bosch-motorsport.jp

**Australia, New Zealand and South Africa:**  
 Robert Bosch Pty. Ltd  
 Motorsport  
 1555 Centre Road  
 Clayton, Victoria, 3168  
 Australia  
 Tel.: +61 (3) 9541 3901  
 motor.sport@au.bosch.com