

# Expansion Board Digital Multichannel Potentiometer

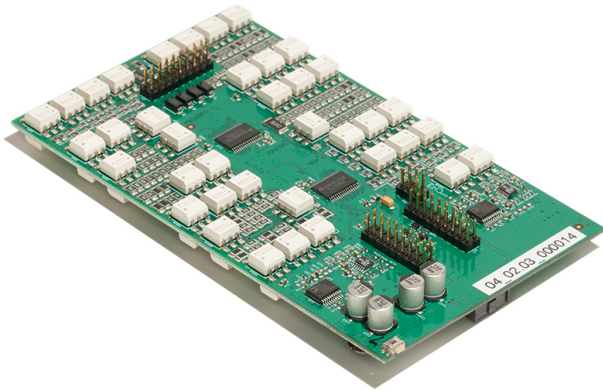

- ▶ 4 independent, galvanically isolated, AC-capable channels
- ▶ Wide range of resistance: 50 Ohm to 500 kOhm
- ▶ High accuracy and 19 Bit Resolution
- ▶ Overcurrent protection
- ▶ Non-mechanical solid-state switches

The **Digital Multichannel Potentiometer Expansion Board** extends the functionality of the **μLC Test System** by seamless integration into an existing device. It offers four independently configurable, galvanically isolated digital potentiometers with a wide range of resistance and excellent accuracy. All four channels feature individual protection by an automatic overcurrent shutdown with automatic retry.

## Application

Emulating Sensor Data

Designed to work for example with the sensor interface L9966 (FlexI)

## Technical Specifications

Maximum voltage on any input referred to μLC-GND -24 to 24 V

## Electrical Characteristics

Parameter	Value	Unit
Minimum Resistance	50	Ohm
Maximum Resistance	500	kOhm
Step Size	1	Ohm
Resolution	19	Bit

## Accuracy

Parameter	Value
Entire Range	±0.5 Ohm ±1 %

## Legal Restrictions

The sale of this product in Mexico is prohibited. Due to embargo restrictions, sale of this product in Russia, Belarus, Iran, Syria, and North Korea is prohibited.

## Ordering Information

**Expansion Board Digital Multichannel Potentiometer**

Order number **F02U.V03.129-01**

Dimensions

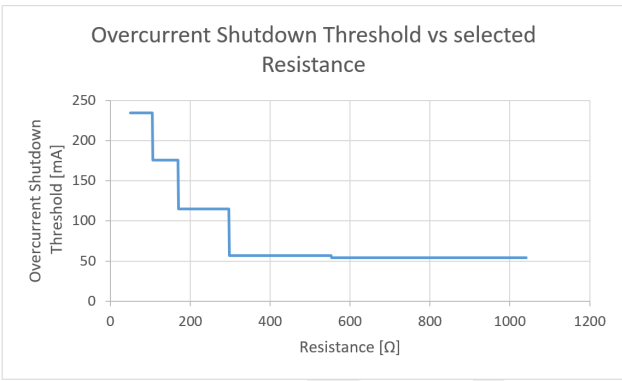

Pinout

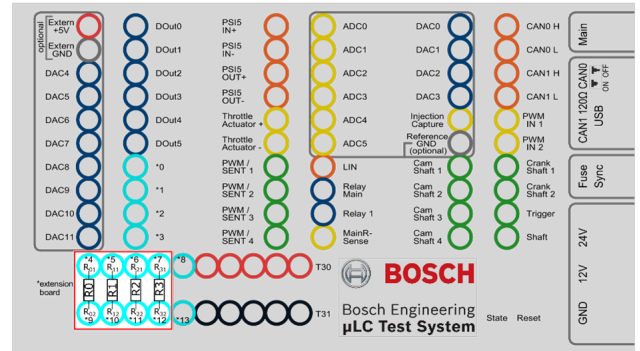

Block diagram:

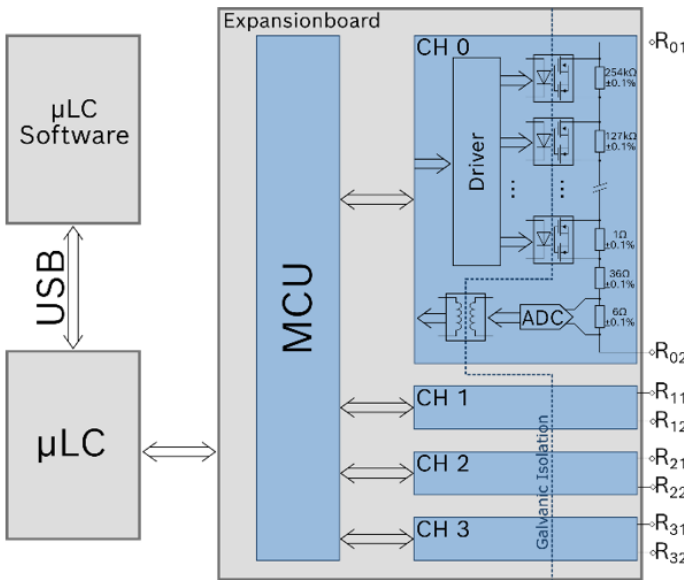

Represented by:

**Europe:**  
 Bosch Engineering GmbH  
 Motorsport  
 Robert-Bosch-Allee 1  
 74232 Abstatt  
 Germany  
 Tel.: +49 7062 911 9101  
 Fax: +49 7062 911 79104  
 motorsport@bosch.com  
 www.bosch-motorsport.de

**North America:**  
 Bosch Engineering North America  
 Motorsport  
 38000 Hills Tech Drive  
 Farmington Hills, MI 48331-3417  
 United States of America  
 Tel.: +1 248 876 2977  
 Fax: +1 248 876 7373  
 motorsport@bosch.com  
 www.bosch-motorsport.com

**Asia-Pacific:**  
 Bosch Engineering Japan K.K.  
 Motorsport  
 18F Queen's Tower C, 2-3-5 Minato  
 Mirai Nishi-ku, Yokohama-shi  
 Kanagawa 220-6218  
 Japan  
 Tel.: +81 45 650 5610  
 Fax: +81 45 650 5611  
 www.bosch-motorsport.jp

**Australia, New Zealand and South Africa:**  
 Robert Bosch Pty. Ltd  
 Motorsport  
 1555 Centre Road  
 Clayton, Victoria, 3168  
 Australia  
 Tel.: +61 (3) 9541 3901  
 motor.sport@au.bosch.com