

FPR Adaptor light



- ▶ Aluminum housing
- ▶ Fits to production type regulators and Motorsport regulators (FPR Mini 2, Mini 5, Mini A)
- ▶ Very light weight

This adaptor offers the opportunity to convert a rail pressure regulator into an inline pressure regulator. The adaptor is able to hold a production type regulator as well as a motorsport regulator. Delivery without regulator.

Application

Fuel compatibility	Gasoline, E85/M100
Operating temperature range	-40 to 120°C
Storage temperature range	-40 to 100°C
Max. vibration	<600 m/s ² at 5 to 250 Hz

Technical Specifications

Mechanical Data

Diameter	50 mm
----------	-------

Dimensions

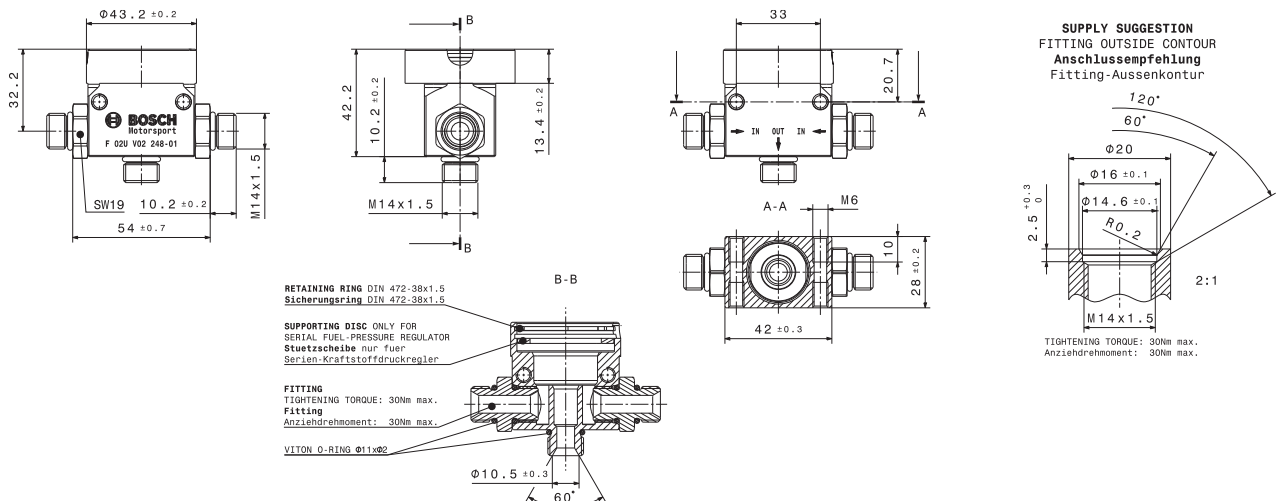

Height	55 mm
Weight	92 g
Mounting	Screw fastening with M6 screws into housing or M5 screws through housing

Connectors and Wires

Connector supply	2 x M14 x 1.5
Connector reflow	M14 x 1.5

Ordering Information

FPR Adaptor light

Order number **F02U.V02.248-01**

Represented by:

Europe:

Bosch Engineering GmbH
Motorsport
Robert-Bosch-Allee 1
74232 Abstatt
Germany
Tel.: +49 7062 911 9101
Fax: +49 7062 911 79104
motorsport@bosch.com
www.bosch-motorsport.de

North America:

Bosch Engineering North America
Motorsport
38000 Hills Tech Drive
Farmington Hills, MI 48331-3417
United States of America
Tel.: +1 248 876 2977
Fax: +1 248 876 7373
motorsport@bosch.com
www.bosch-motorsport.com

Asia-Pacific:

Bosch Engineering Japan K.K.
Motorsport
18F Queen's Tower C, 2-3-5 Minato
Mirai Nishi-ku, Yokohama-shi
Kanagawa 220-6218
Japan
Tel.: +81 45 650 5610
Fax: +81 45 650 5611
www.bosch-motorsport.jp

Australia, New Zealand and South

Africa:
Robert Bosch Pty. Ltd
Motorsport
1555 Centre Road
Clayton, Victoria, 3168
Australia
Tel.: +61 (3) 9541 3901
motor.sport@au.bosch.com