

Ignition Coil C90i-pro evo



- ▶ Max. 40 kV
- ▶ Max. 90 mJ
- ▶ Boosted spark current
- ▶ Max. 15,000 1/min
- ▶ Developed for engines with high gas turbulences

This single fire coil was developed for engines that need a stable spark because of their higher turbulences at the air fuel mixture inside the cylinder. It is designed for direct cylinder head mounting. The main benefits of this high performance coil are its high energy capability and a very good provided high voltage.

Application

Spark energy	≤ 90 mJ
Primary current	≤ 16 A
Operating temperature range outer core	0 to 160°C
Storage temperature range	-40 to 100°C
Max. vibration	≤ 480 m/s ² at 50 to 2,000 Hz

Technical Specifications

Mechanical Data

Length	168 mm
Weight w/o wire	250 g
Mounting	screw fastening

Electrical Data

Primary resistance	185 mOhm
Secondary resistance	Incapable of measurement
High voltage rise time	≤ 5.0 kV/μs
Max. high voltage at 1 MOhm 10 pF	≤ 40 kV
Spark current	≤ 265 mA
Spark duration at 1 kV 1 MOhm	≤ 0.65 ms

Noise suppression	Inductive
Suppression diode / EFU	Internal

Characteristic

Measured with power stage	IGBT IRG4BC40S (U _{ce} =600 V)
---------------------------	---

Connectors and Wires

Connector	On request
Mating connector	On request
Pin 1	U _{batt} red
Pin 2	ECU ignition power stage blue
Pin 3	Engine GND black
Wire length	100 cm
Wire size	AWG 20/22
For spark plugs	Ceramic diameter d = 10 mm

Various motorsport and automotive connectors are available on request.

Please specify the required wire length and the length of the spark plug connector with your order

Characteristic dwell times [ms]

U _{batt}	I _{primary}					
	10 A	12 A	15 A	16 A	17 A	20 A
6 V	3.90	5.50	9.80	12.8		
8 V	2.15	2.90	4.10	4.50	4.80	
10 V	1.50	1.96	2.66	2.86	3.03	3.38
12 V	1.15	1.50	2.00	2.13	2.24	2.46
14 V	0.94	1.20	1.60	1.70	1.78	1.94
16 V	0.79	1.00	1.32	1.41	1.48	1.60

16.5 V	0.76	0.97	1.27	1.35	1.42	1.54
18 V	0.68	0.69	1.14	1.21	1.26	1.37

Measured values are without loom resistance. Loom resistance must be less than the primary resistance. The needed dwell time is to be verified through current measurement

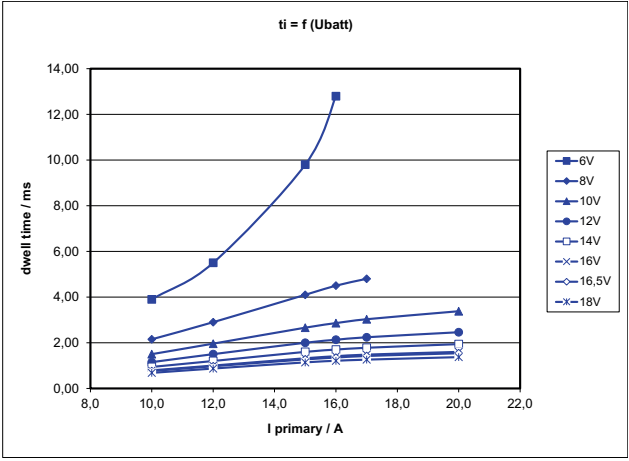

Dwell time Spark energy and provided high voltage

I prim.	Spark energy	-duration	-current	Hi voltage
10 A	36.5 mJ	0.366 ms	167 mA	28 kV
12 A	55 mJ	0.446 ms	197 mA	31.3 kV
15 A	86.2 mJ	0.567 ms	246 mA	35 kV
16 A	93.6 mJ	0.592 ms	263 mA	35.6 kV
17 A	100.7 mJ	0.62 ms	274 mA	36 kV
20 A	116 mJ	0.67 ms	305 mA	36.6 kV

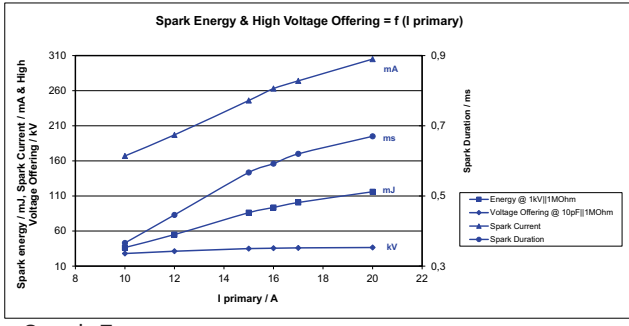

Spark Energy

Installation Notes

During mounting of the spark plug please pay attention that full clamping and proper contacts are made to ensure safe connection between coil and spark plug.

This coil is only for use with engine control units having an integrated ignition power stage, e.g. IGBT IRG4BC40S or BIP.

For technical reasons the values of the coils may vary.

Please regard the specified limit values (see "Electrical Data").

Usage above Iprim = 16 A or 40 kV may reduce the lifetime.

Please find further application hints in the offer drawing at our homepage.

Design Note

We strongly recommend the design of the spark plug shaft has to ensure that there are no sharp edges in the shaft geometry due to design or machining. Only in compliance with this recommendation, a proper function can be ensured.

Ordering Information

Ignition Coil C90i-pro evo
Order number **F037.000.997**

Dimensions

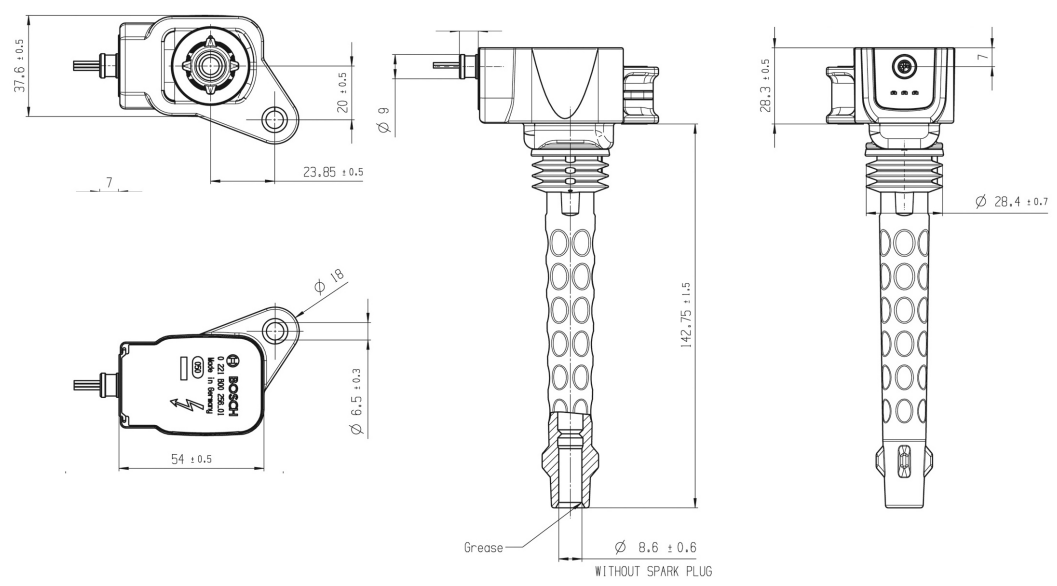

Represented by:

Europe:

Bosch Engineering GmbH
Motorsport
Robert-Bosch-Allee 1
74232 Abstatt
Germany
Tel.: +49 7062 911 9101
Fax: +49 7062 911 79104
motorsport@bosch.com
www.bosch-motorsport.de

North America:

Bosch Engineering North America
Motorsport
38000 Hills Tech Drive
Farmington Hills, MI 48331-3417
United States of America
Tel.: +1 248 876 2977
Fax: +1 248 876 7373
motorsport@bosch.com
www.bosch-motorsport.com

Asia-Pacific:

Bosch Engineering Japan K.K.
Motorsport
18F Queen's Tower C, 2-3-5 Minato
Mirai Nishi-ku, Yokohama-shi
Kanagawa 220-6218
Japan
Tel.: +81 45 650 5610
Fax: +81 45 650 5611
www.bosch-motorsport.jp

Australia, New Zealand and South

Africa:
Robert Bosch Pty. Ltd
Motorsport
1555 Centre Road
Clayton, Victoria, 3168
Australia
Tel.: +61 (3) 9541 3901
motor.sport@au.bosch.com