

# Ignition Coil P65



- ▶ Max. 35 kV
- ▶ Max. 65 mJ
- ▶ Max. 10,000 1/min
- ▶ Developed for GDI engines

This single fire coil is a low cost concept, designed to get connected to the spark plug via a high voltage wire. The high voltage connector is specified according to the SAE standard.

The performance of the coil fulfills the demands of modern GDI engines.

The main benefits of this product are the high packaging flexibility and its high electrical performance at low costs.

## Application

Spark energy	≤ 65 mJ
Primary current	≤ 7.5 A
Operating temperature range at outer core	-20 to 140°C
Storage temperature range	-40 to 100°C
Max. vibration	≤ 250 m/s <sup>2</sup> at 5 to 2,500 Hz

## Technical Specifications

### Mechanical Data

Length	180 mm
Weight w/o wire	225 g
Mounting	Screw fastening
Fits to spark plugs with a ceramic diameter of 10 mm	

### Electrical Data

Primary resistance	570 mOhm
Secondary resistance	Incapable of measurement
High voltage rise time	≤ 1.9 kV/μs
Max. high voltage at 1 MOhm    10 pF	≤ 35 kV

Spark current	≤ 74 mA
Spark duration at 1 kV    1 MOhm	≤ 2.0 ms
Noise suppression	Inductive and 1 kOhm resistance
Suppression diode / EFU	Integrated

### Characteristic

Measured with power stage	IGBT IRG4BC40S (U <sub>ce</sub> = 600 V)
---------------------------	--

### Connectors and Wires

Connector	Tyco AMP
Mating connector	D261.205.350-01
Pin 1	Engine GND
Pin 2	U <sub>batt</sub>
Pin 3	ECU ignition power stage

### Characteristic dwell times [ms]

U <sub>batt</sub>	I <sub>primary</sub>					
	5.0 A	6.0 A	7.0 A	7.5 A	8.0 A	8.5 A
<b>6 V</b>	8.74	18.5				
<b>8 V</b>	4.5	6.4	9	10.8	13.9	
<b>10 V</b>	3.1	4.2	5.4	6	6.6	7.2
<b>12 V</b>	2.36	3.1	3.88	4.25	4.63	4.92
<b>14 V</b>	1.9	2.48	3.05	3.32	3.57	3.77
<b>16 V</b>	1.61	2.06	2.53	2.73	2.93	3.08
<b>18 V</b>	1.55	2	2.43	2.62	2.81	2.95
<b>20 V</b>	1.39	1.77	2.16	2.33	2.48	2.6
<b>22 V</b>	1.22	1.54	1.88	2.02	2.15	2.26
<b>24 V</b>	0.97	1.23	1.49	1.6	1.71	1.78

Measured values are without loom resistance. Loom resistance must be less than the primary resistance. The needed dwell time is to be verified through current measurement

**Spark energy and provided high voltage**

I prim.	Spark energy	-duration	-current	Hi voltage
5 A	37.8 mJ	1.46 ms	49 mA	24.3 kV
6 A	54.5 mJ	1,74 ms	59 mA	28.9 kV
7 A	69.8 mJ	1.97 ms	69 mA	33.2 kV
7.5 A	77.6 mJ	2.04 ms	74 mA	35.8 kV
8 A	83.0 mJ	2.11 ms	77 mA	37.7 kV
8.5 A	88.0 mJ	2.16 ms	81 mA	39.0 kV

**Installation Notes**

During mounting of the spark plug please pay attention that full clamping and proper contacts are made to ensure safe connection between coil and spark plug.

**Dimensions**

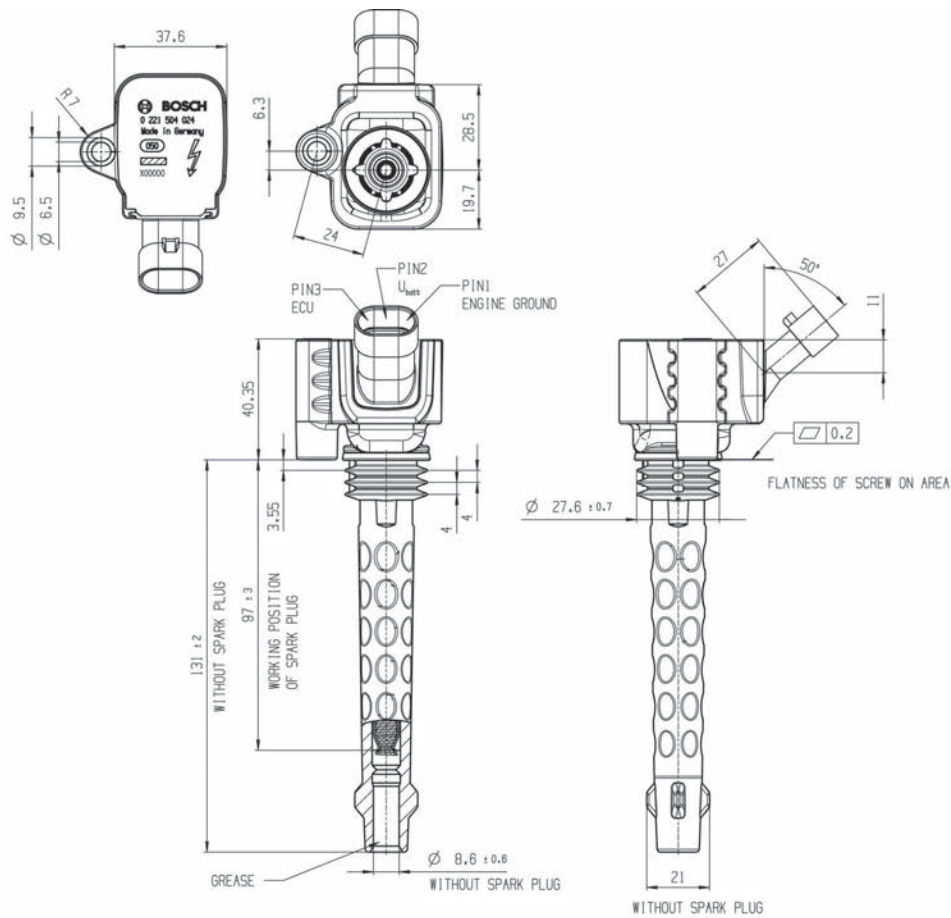

The coil P65 has no integrated transistor and requires an ECU with internal ignition power stages, e.g. IGBT IRG4BC40S or BIP.

For technical reasons the values of the coils may vary.

Please regard the specified limit values.

Please find further application hints in the offer drawing at our homepage.

In case of ignition-caused malfunctions, please use screened sensor wires.

**Design Note**

We strongly recommend the design of the spark plug shaft has to ensure that there are no sharp edges in the shaft geometry due to design or machining. Only in compliance with this recommendation, a proper function can be ensured.

**Ordering Information**

**Ignition Coil P65**

Order number **0221.504.024**

**Represented by:**

**Europe:**

Bosch Engineering GmbH  
Motorsport  
Robert-Bosch-Allee 1  
74232 Abstatt  
Germany  
Tel.: +49 7062 911 9101  
Fax: +49 7062 911 79104  
motorsport@bosch.com  
www.bosch-motorsport.de

**North America:**

Bosch Engineering North America  
Motorsport  
38000 Hills Tech Drive  
Farmington Hills, MI 48331-3417  
United States of America  
Tel.: +1 248 876 2977  
Fax: +1 248 876 7373  
motorsport@bosch.com  
www.bosch-motorsport.com

**Asia-Pacific:**

Bosch Engineering Japan K.K.  
Motorsport  
18F Queen's Tower C, 2-3-5 Minato  
Mirai Nishi-ku, Yokohama-shi  
Kanagawa 220-6218  
Japan  
Tel.: +81 45 650 5610  
Fax: +81 45 650 5611  
www.bosch-motorsport.jp

**Australia, New Zealand and South**

**Africa:**  
Robert Bosch Pty. Ltd  
Motorsport  
1555 Centre Road  
Clayton, Victoria, 3168  
Australia  
Tel.: +61 (3) 9541 3901  
motor.sport@au.bosch.com