

Pressure Sensor Fluid PSC-260



The PSC-260 is specially designed to measure absolute pressure in gasoline direct injection applications. This sensor is also compatible with other kind of fluids e.g. Diesel, engine oil, transmission oil or brake fluid.

The sensor uses a thin layer technique to achieve high accuracy pressure measurements. The stainless steel measuring cells with piezoresistive bridges are hermetically welded with stainless steel pressure ports. The internal reference ensures ambient pressure independent measurements.

The main benefits of this sensor are its high accuracy, its wide measurement range and its robust and compact design.

Application

Application	0 to 260 bar (a)
Pressure reference type	absolute
Max. pressure	320 bar
Operating temp. range	-40 to 130°C (140°C)
Media temp. range	-40 to 130°C (140°C)
Storage temp. range	-30 to 60°C
Max. vibration	560 m/s ² at 800 to 900 Hz 350 m/s ² at 1.000 to 2.500 Hz

Technical Specifications

Mechanical Data

Male thread	M10 x 1
Wrench size	27 mm
Installation torque	22 Nm in steel 32.5 Nm in aluminum

- ▶ Application: 0 to 260 bar
- ▶ Response time: 2 ms
- ▶ Pressure reference type: Absolut
- ▶ Power supply: 5 V
- ▶ Weight: 35 g

Weight w/o wire	35.2 g
Sealing	sealed cone

Electrical Data

Power supply U_s	4.75 to 5.25 V
Max power supply U_s max	16 V
Full scale output U_A	10 to 90 % U_s ratio metric
Current I_s	12 mA

Characteristic

Load capacity	10 nF
Output resistance	10 Ohm
Tolerance (FS)	+ 1 % (0 to 100°C) + 1.5 % (-40 to 0°C and 100 to 130°C)
Sensitivity	15.38 mV/bar at $U_s = 5$ V
Offset	500 mV at $U_s = 5$ V

Connectors and Wires

Connector	ASL606-05PC-HE
Mating connector	F 02U 000 228-01 ASL006-05SC-HE
Pin 1	-
Pin 2	Gnd
Pin 3	Sig
Pin 4	U_s
Pin 5	-
Various motorsport and automotive connectors are available on request.	
Please specify the required wire length with your order.	
Sleeve	DR-25

Wire length L	13 to 95 cm
---------------	-------------

Installation Notes

- The PSC-260 can be connected directly to most control units. Please consider the TCI for the electrical connection of the sensor.
- The sensor has a protection for overvoltage, reverse polarity and short-circuit.
- Please do not fix the sensor directly to the engine block to avoid undesired strong vibrations.
- Each mounting orientation is possible.
- Please consider using the adapter F 02U 002 711-01.
- The sensor meets all EMV, EMC and ESD automotive standards.

Please find further application hints in the offer drawing and free download of the sensor configuration file (*.sdf) for the Bosch Data Logging System at our homepage.

Safety Note
The sensor is not intended to be used for safety related applications without appropriate measures for signal validation in the application system.

Ordering Information

- Pressure Sensor Fluid PSC-260**
Order number **F 02U V00 990-03**
- Accessories**
- Adapter**
Order number **F 02U 002 711-01**

Dimensions

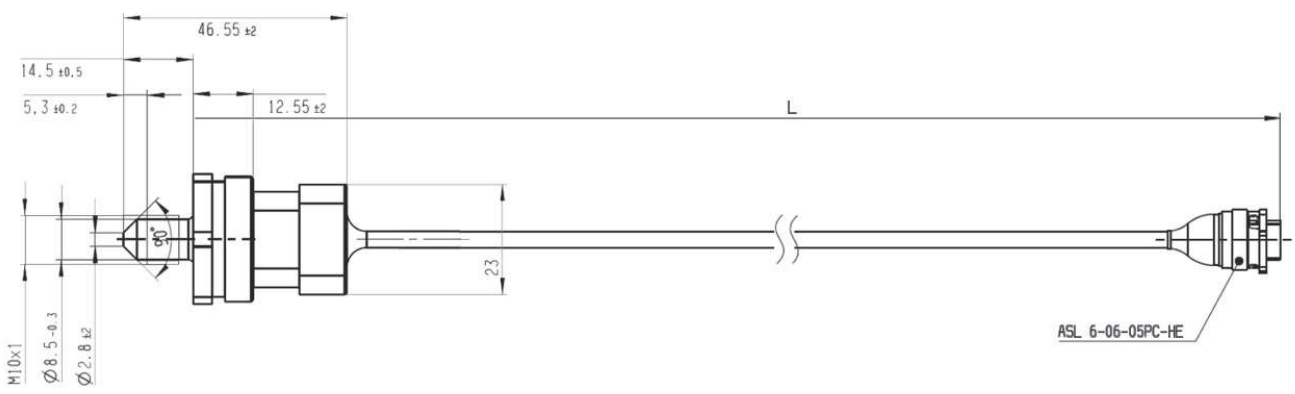

Sensor

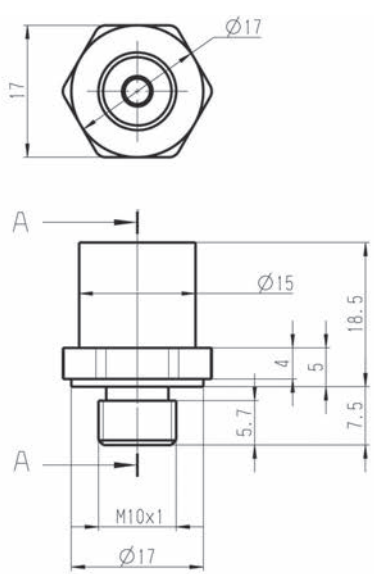

Adapter

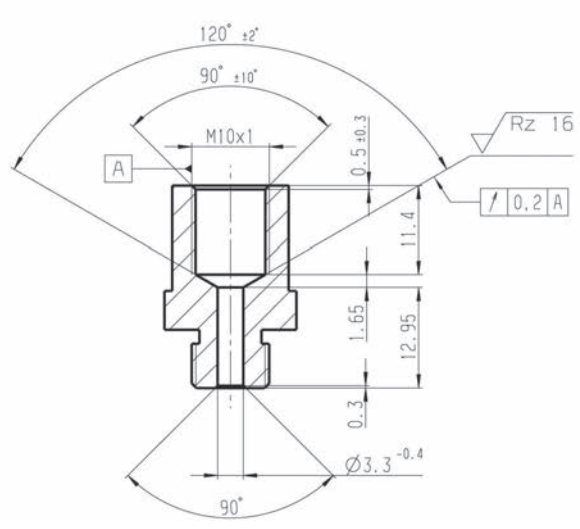

Represented by:

Europe:

Bosch Engineering GmbH
Motorsport
Robert-Bosch-Allee 1
74232 Abstatt
Germany
Tel.: +49 7062 911 9101
Fax: +49 7062 911 79104
motorsport@bosch.com
www.bosch-motorsport.de

North America:

Bosch Engineering North America
Motorsport
38000 Hills Tech Drive
Farmington Hills, MI 48331-3417
United States of America
Tel.: +1 248 876 2977
Fax: +1 248 876 7373
motorsport@bosch.com
www.bosch-motorsport.com

Asia-Pacific:

Bosch Engineering Japan K.K.
Motorsport
18F Queen's Tower C, 2-3-5 Minato
Mirai Nishi-ku, Yokohama-shi
Kanagawa 220-6218
Japan
Tel.: +81 45 650 5610
Fax: +81 45 650 5611
www.bosch-motorsport.jp

Australia, New Zealand and South

Africa:
Robert Bosch Pty. Ltd
Motorsport
1555 Centre Road
Clayton, Victoria, 3168
Australia
Tel.: +61 (3) 9541 3901
motor.sport@au.bosch.com